

# M10

N-TopCon

Bifacial Module with Transparent Backsheet

## AOX 78M10HC

# 610W-630W

- Based on M10-182mm solar cells.
- Higher module quality ensures long-term reliability
- MBB Technology, better light trapping and current collection to improve module power output and reliability.
- Excellent Anti-PID performance guarantee via optimized mass production process and materials control

WORLD SHINES BECAUSE OF YOU

## N-TopCon Technology Innovation

Selective Passivation Contact

The key technology determines the maximum efficiency



## PRODUCT Warranty

12-year Warranty for Materials and Processing  
30-year Warranty for Extra Linear Power Output

## PRODUCT Certifications

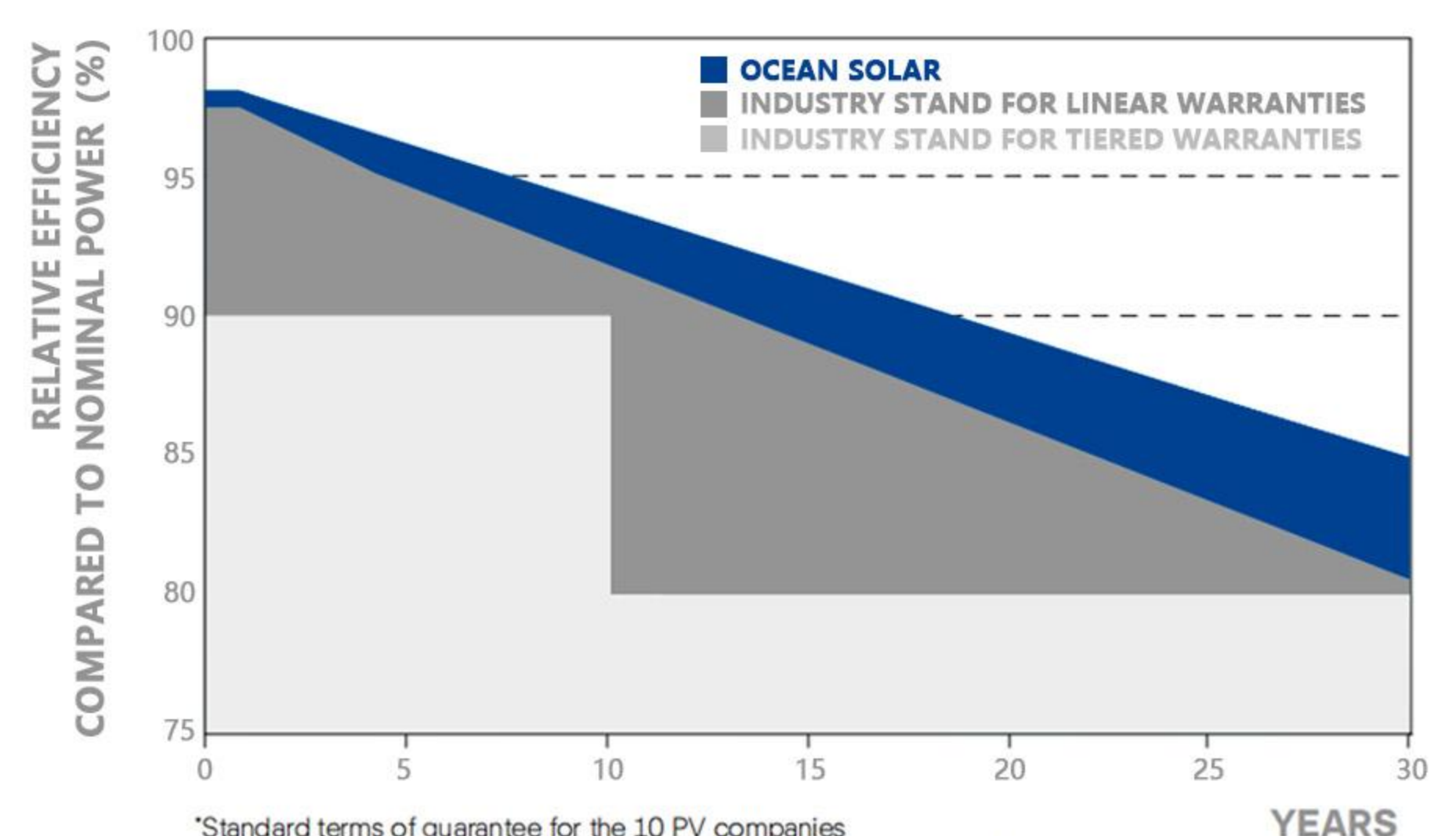
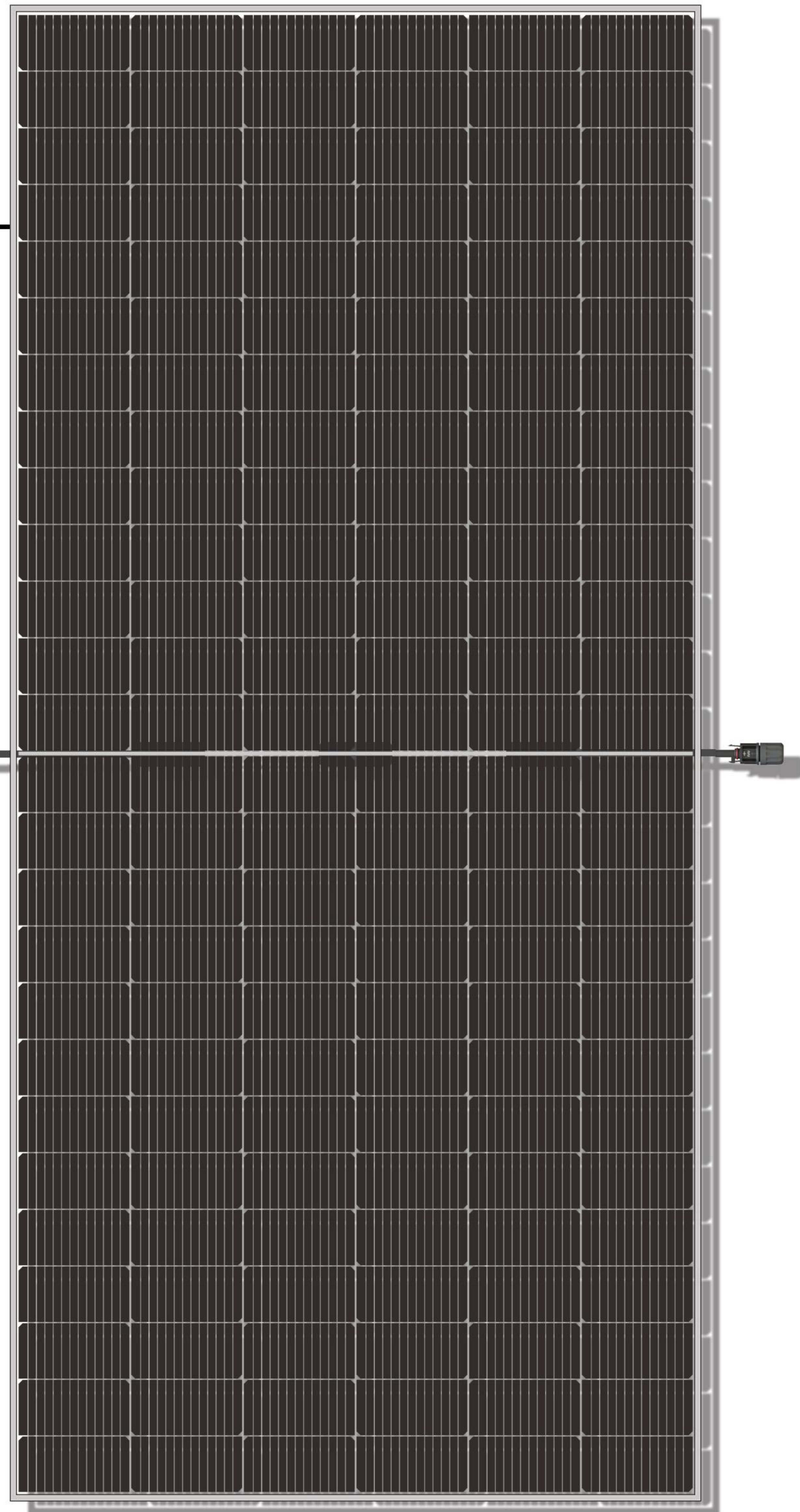

\*Standard terms of guarantee for the 10 PV companies with the highest production capacity in 2014 (as at: September 2014)



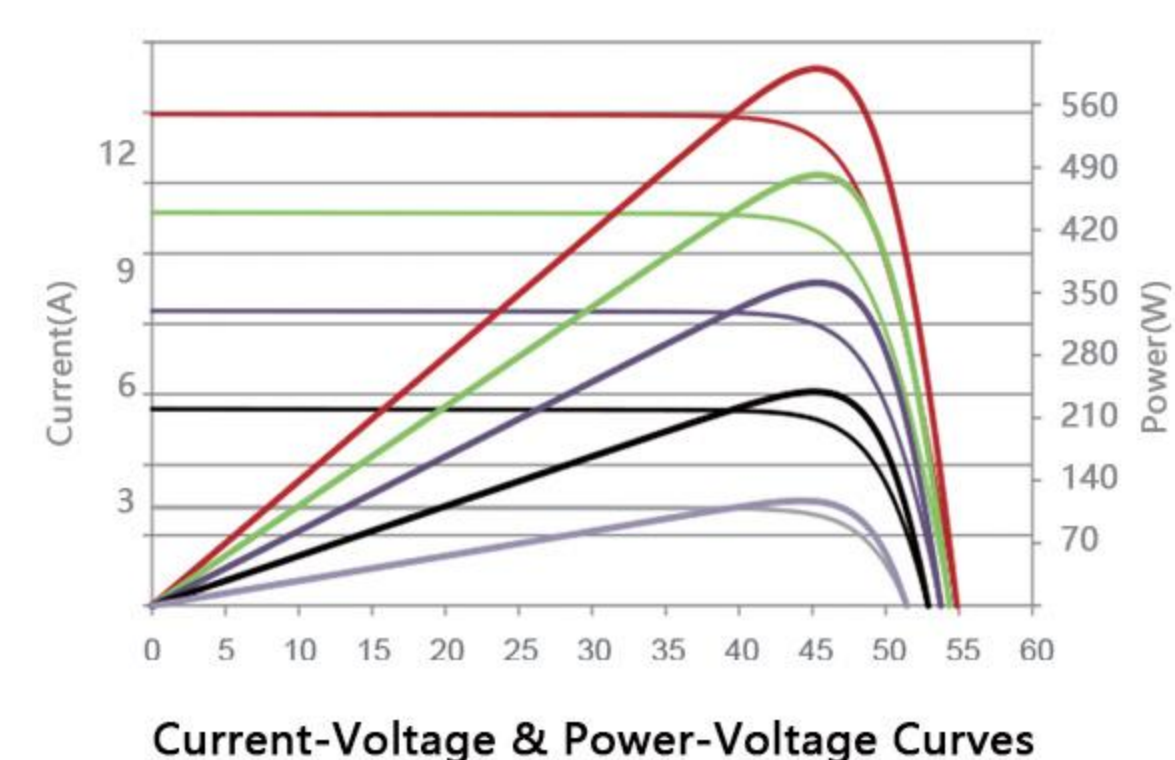
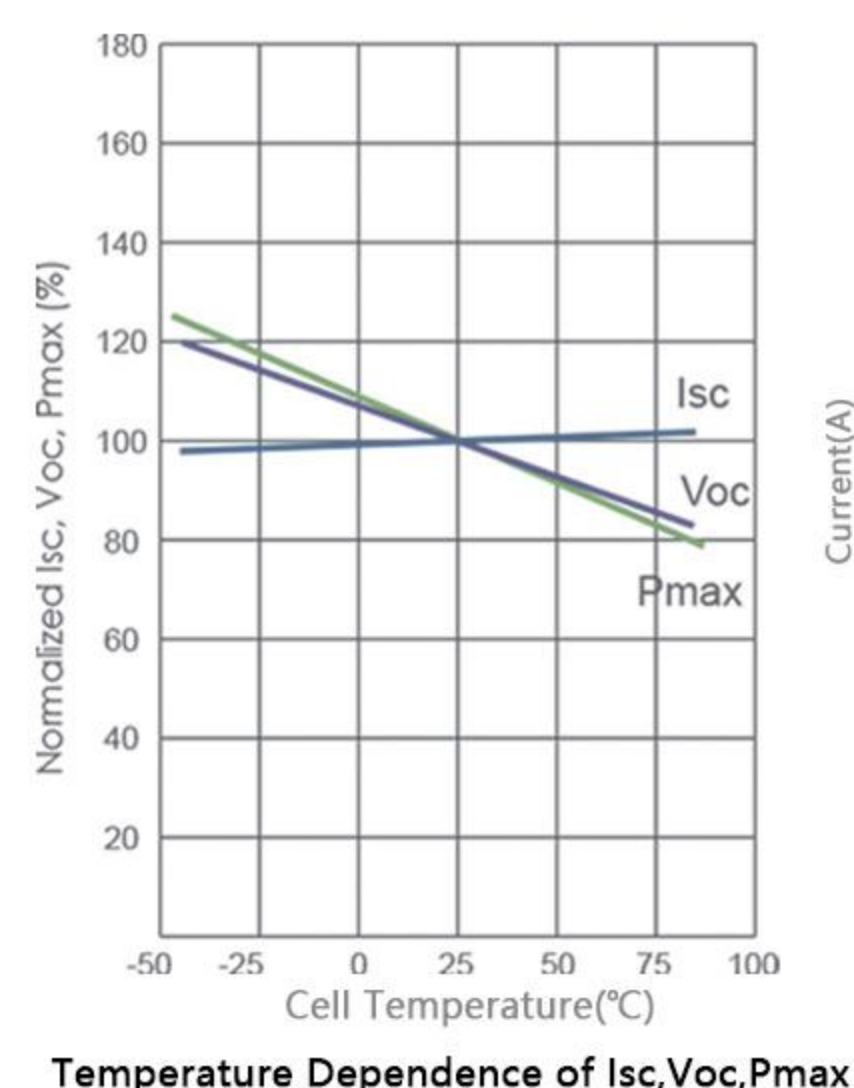
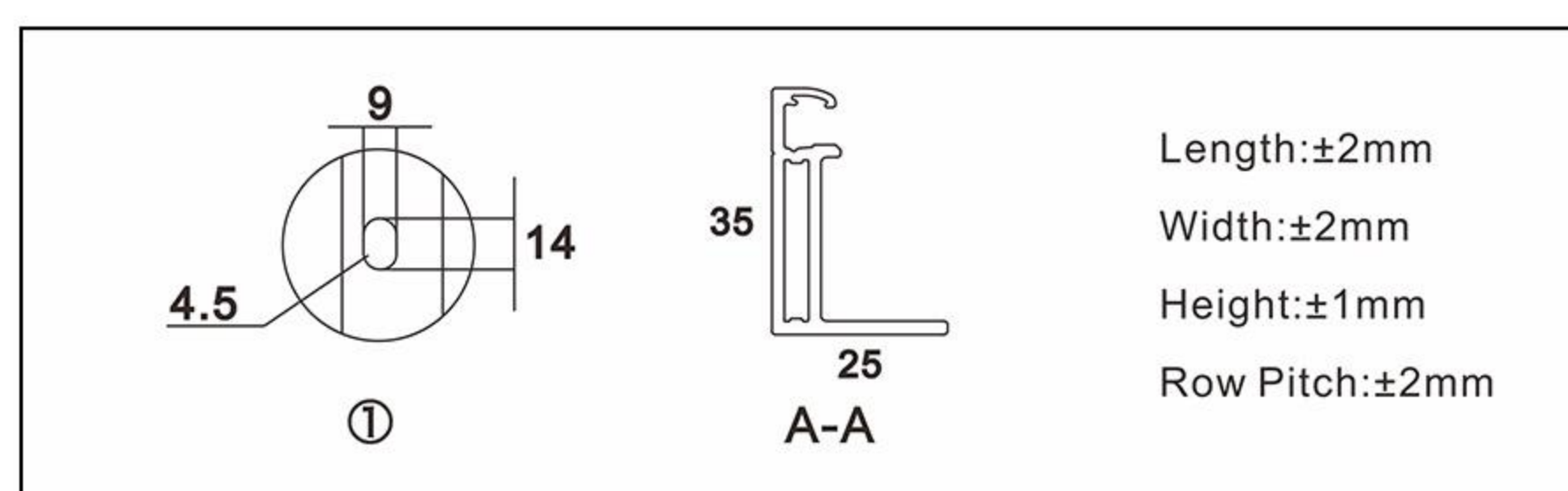
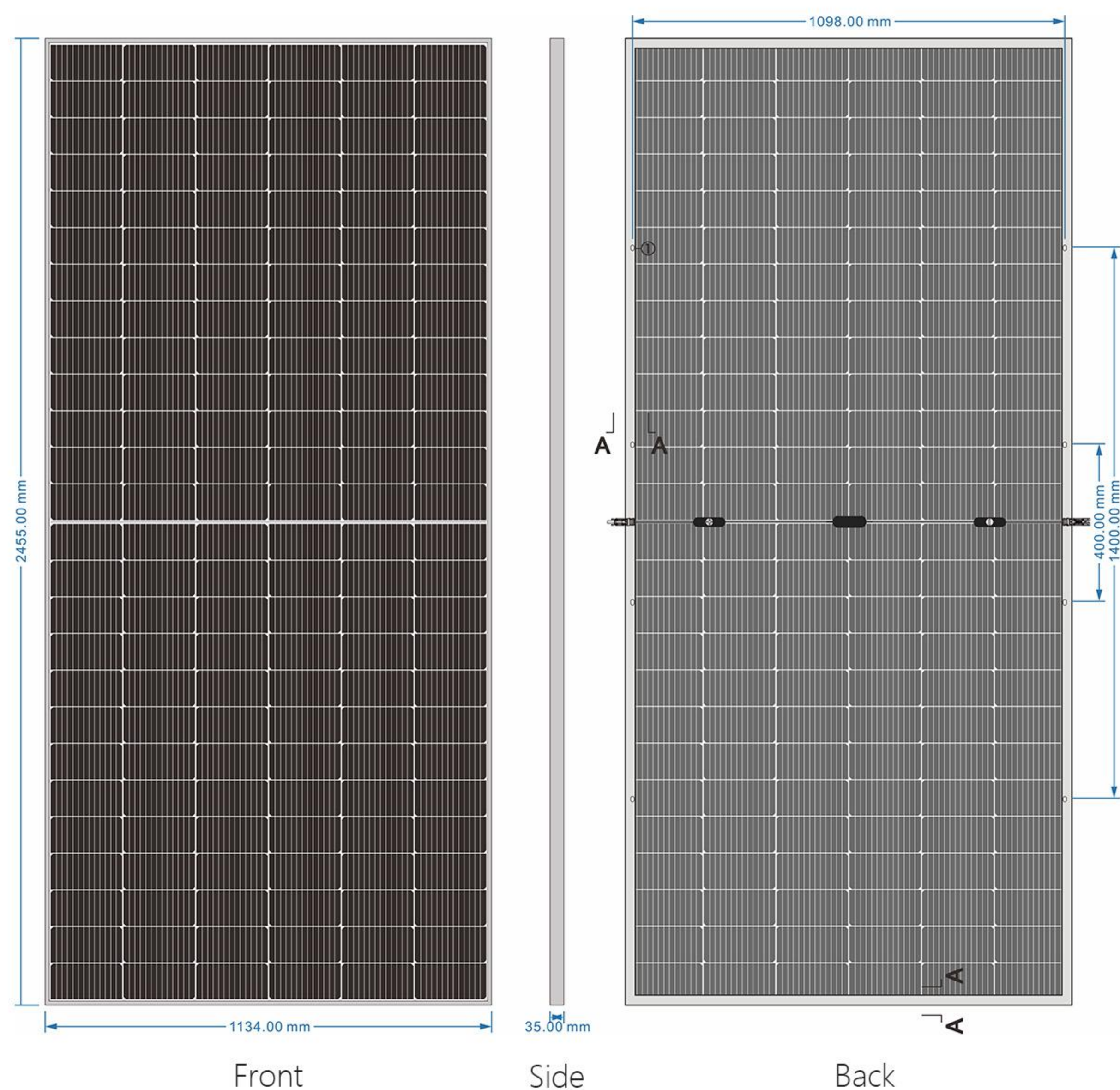

## Electrical Characteristics

STC: AM1.5 1000W/m<sup>2</sup> 25°C NOCT: AM1.5 800W/m<sup>2</sup> 20°C 1m/s Test uncertainty for Pmax: ±3%

Module Type	AOX-78M10HC610W		AOX-78M10HC615W		AOX-78M10HC620W		AOX-78M10HC625W		AOX-78M10HC630W	
	STC	NOCT	STC	NOCT	STC	NOCT	STC	NOCT	STC	NOCT
Testing Condition	STC	NOCT	STC	NOCT	STC	NOCT	STC	NOCT	STC	NOCT
Maximum Power (Pmax/W)	610Wp	459Wp	615Wp	462Wp	620Wp	465Wp	625Wp	468Wp	630Wp	471Wp
Voltage at Maximum Power (Vmp/V)	45.59V	42.28V	45.69V	42.39V	45.79V	42.50V	45.89V	42.61V	45.99V	42.72V
Current at Maximum Power (Imp/A)	13.38A	10.85A	13.46A	10.91A	13.54A	10.94A	13.62A	10.98A	13.70A	11.03A
Open Circuit Voltage (Voc/V)	55.25V	52.48V	55.40V	52.62V	55.55V	52.79V	55.70V	52.93V	55.85V	53.07V
Short Circuit Current (Isc/A)	14.11A	11.39A	14.18A	11.45A	14.25A	11.51A	14.32A	11.57A	14.39A	11.63A
Module Efficiency(%)	21.90%		22.10%		22.30%		22.50%		22.60%	

## Mechanical Parameters

Cell Orientation	6*26 (156) solar half cells
Junction Box	IP 68 3 diodes
Output Cable	4.0mm <sup>2</sup> solar cable(IEC) (+)≥350mm (-)≥350mm or customized
Glass	3.2mm, High Transmission, AR Coated Heat Strengthened Glass
Frame	35mm Anodized Aluminium Alloy
Weight	29.0kg
Dimension	2455*1134*35mm
Packaging	31pcs/pallets,620pcs/ 40HQ Container

## Mechanical Loading

Front Side Maximum Static Loading	5400Pa
Rear Side Maximum Static Loading	2400Pa
Hailstone Test	25mm Hailstone at the speed of 23m/s

## Bifacial Output-Rearside Power Gain

5%	Maximum Power (Pmax)	640W	646W	651W	656W	662W
	Module Efficiency STC (%)	23.00%	23.21%	23.42%	23.63%	23.73%
15%	Maximum Power (Pmax)	702W	707W	713W	719W	725W
	Module Efficiency STC (%)	25.19%	25.42%	25.65%	25.88%	25.99%
25%	Maximum Power (Pmax)	763W	769W	775W	781W	788W
	Module Efficiency STC (%)	27.38%	27.63%	27.88%	28.13%	28.25%

## Operating Parameters

Operational Temperature	-40~+85 °C
Power Output Tolerance	0~5W
Voc and Isc Tolerance	±3%
Maximum System Voltage	1000/1500VDC(IEC)
Maximum Series Fuse Rating	25A
Nominal Operating Cell Temperature	45±2°C
Protection Class	Class II
Fire Rating	UL type 1 or 2 IEC Class C

## Temperature Ratings (STC)

Temperature Coefficient of Isc	0.046%/°C
Temperature Coefficient of Voc	-0.25%/°C
Temperature Coefficient of Pmax	-0.30%/°C

## Product Warranty

Warranty for Materials and Processing	12 Year
Warranty for Extra Linear Power Output	30 Year

## Product Certifications



Ocean Solar Co.,Ltd  
E-mail: info@oceansolar.cn  
Web: www.oceansolar.cn

© 2022 Ocean Solar All rights reserved.

Specifications included in this datasheet are subject to change without notice.

